

4

3

2

1

F

F

E

E

D

D

C

C

B

B

A

A

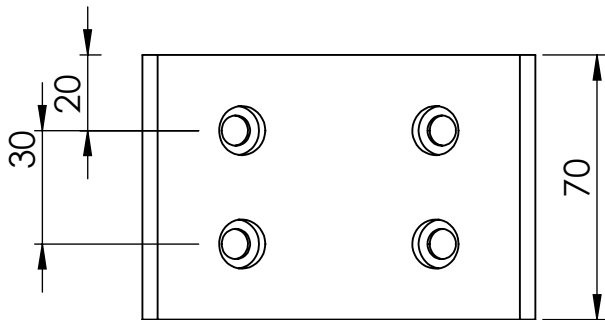
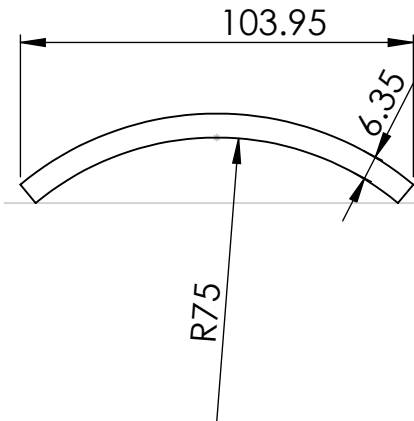

UNLESS OTHERWISE SPECIFIED:
 DIMENSIONS ARE IN MILLIMETERS
 SURFACE FINISH:
 TOLERANCES:
 LINEAR:
 ANGULAR:

FINISH:

DEBURR AND
 BREAK SHARP
 EDGES

DO NOT SCALE DRAWING

REVISION

	NAME	SIGNATURE	DATE	
DRAWN				
CHK'D				
APPV'D				
MFG				
Q.A				

TITLE: **BRAKE
 LINER..SLDDRW 2D**

MATERIAL:
ASBESTOS

DWG NO.

A4

WEIGHT:

SCALE:1:2

SHEET 1 OF 1

4

3

2

1