

FRONT VIEW

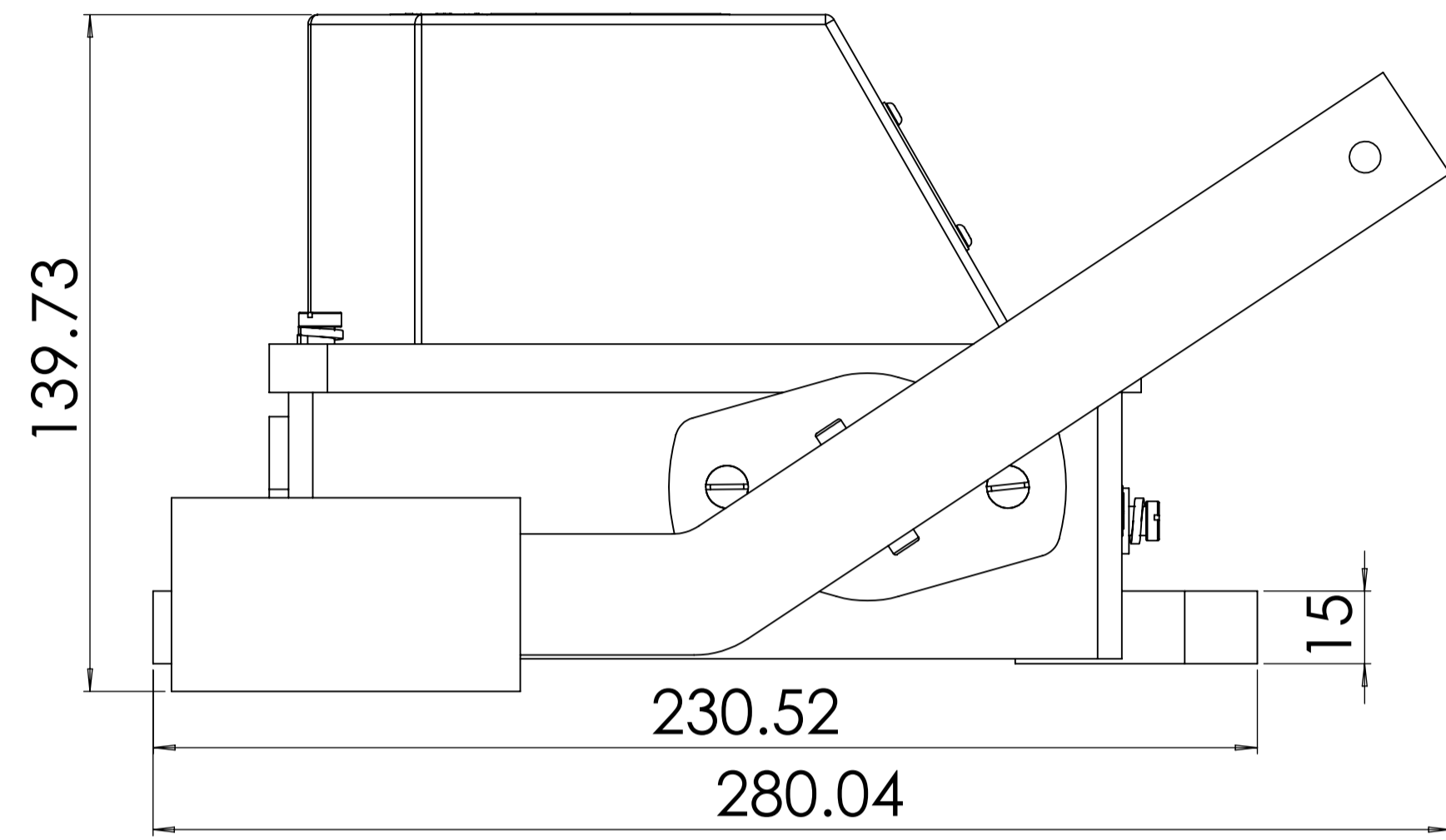

SIDE VIEW

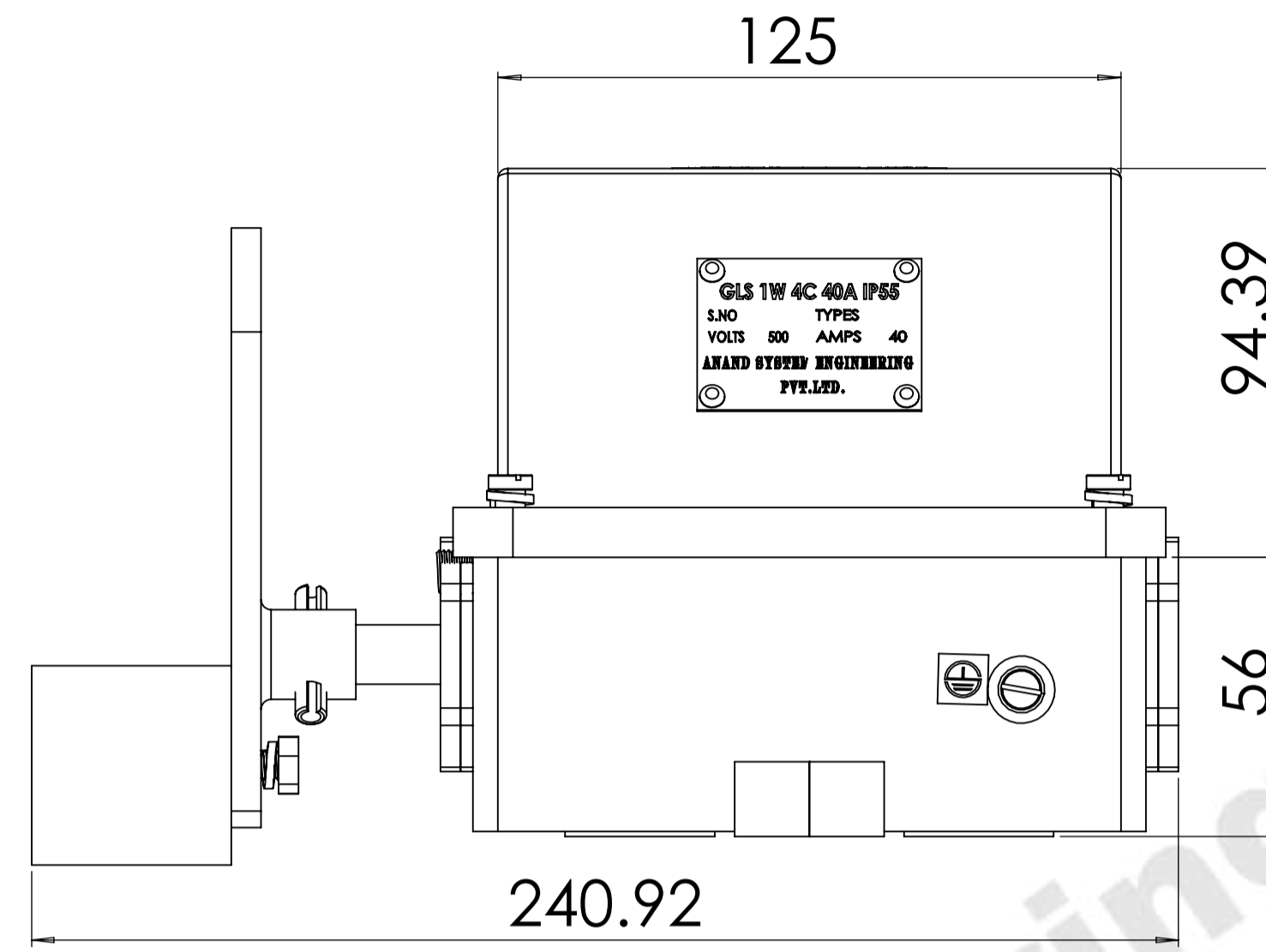

180

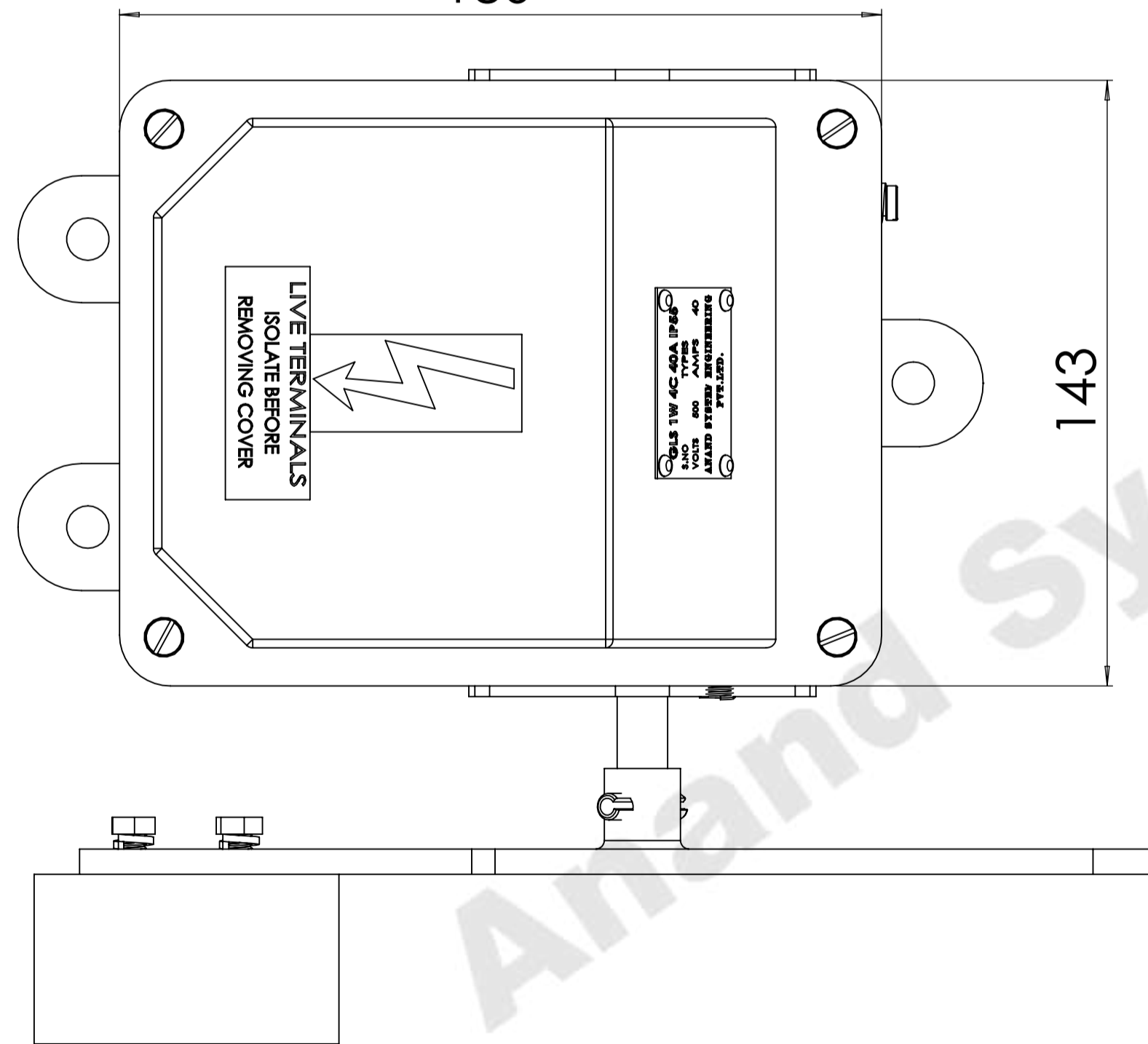

TOP VIEW

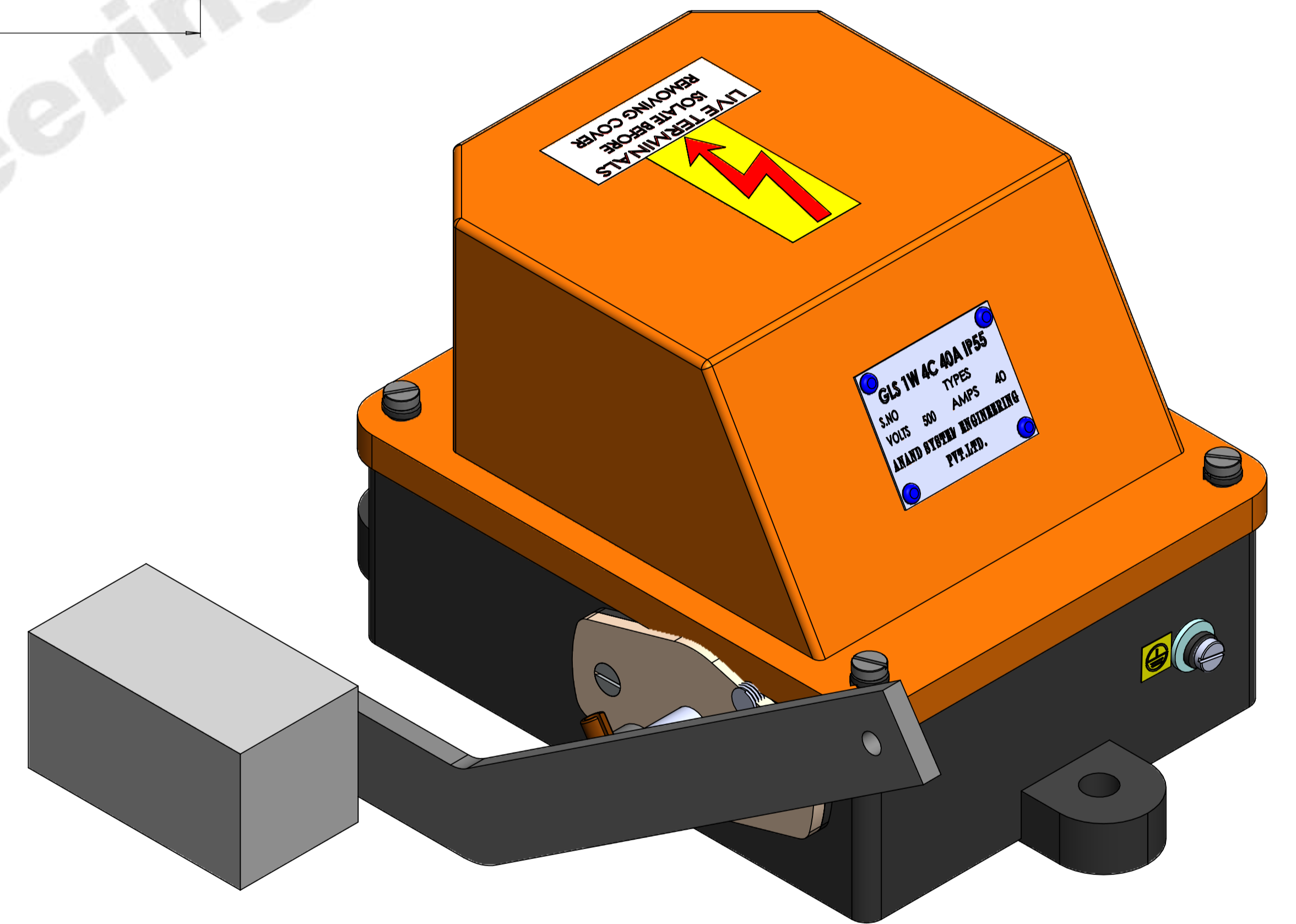

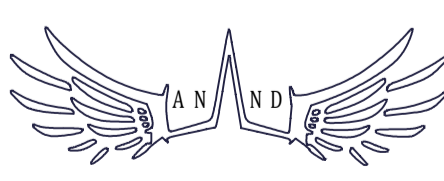
COMPANY NAME:		ANAND SYSTEM ENGINEERING PVT LTD		DO NOT SCALE DRAWING	REVISION:
		Email id: info@anandcontrol.in CONTACT NO: 9137620579		TITLE: <b>GRAVITY LIMIT SWITCH 1W 4C IP55 ASSEMBLY 2D</b>	
DWG NO.:		DATE: 18-12-2024		SIGNATURE:	
DRAWN: SAURABH	CHECKED:	MATERIAL:	WEIGHT:	SCALE:	SHEET: 1 OF 1

# EXPLODED VIEW

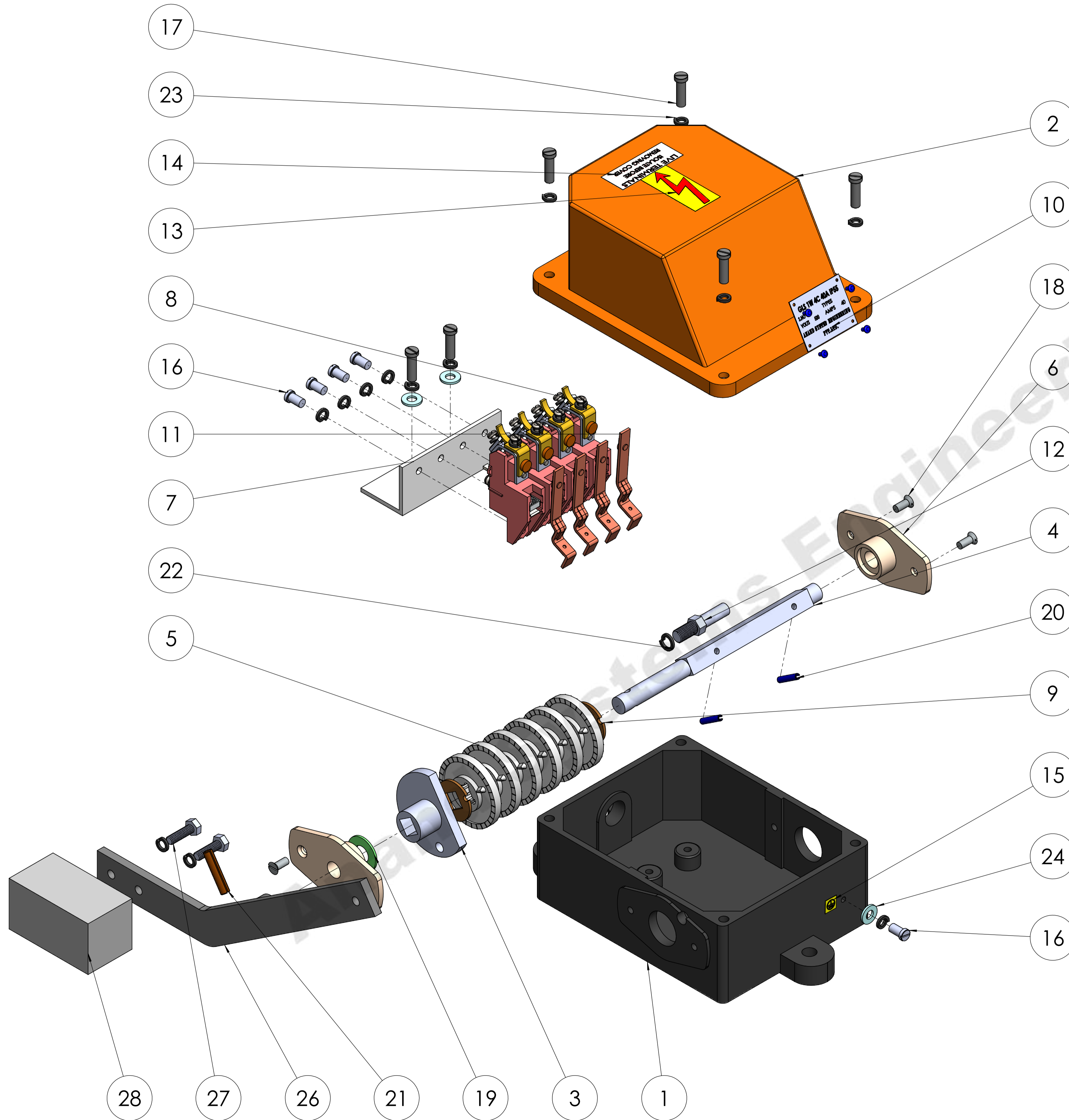

ITEM NO.	PART NUMBER	DESCRIPTION	MATERIAL	QTY.
1	BOTTOM COVER	172X135X61	ALUMINIUM DIE CAST	1
2	TOP COVER	180X143X78	ALUMINIUM DIE CAST	1
3	PLASTIC STOPPER	60X25X12	PLASTIC	1
4	SHAFT	SQ SHAFT 12X180X MIDDLE 110MM	M.S.	1
5	CAM	CAM	NYLON	6
6	END BUSH	Ø 12MM	NYLON	2
7	CONTACT STRIP	90MM LONG THK-3MM	ALUMINIUM	1
8	CONTACT BLOCK	CONTACT BLOCK ASSEMBLY	-	4
9	LOCK WASHER	LOCK WASHER 12X12 SQ 29X1.5MM	M.S.	2
10	NAME PLATE	45X35X0.5(4 HOLES 2MM)	ALUMINIUM	1
11	CONTACT STRIP	CONTACT BREAK STRIP	BRASS	4
12	STOPPER PIN	HEX ROD 11X50, M8 THREAD	M.S.	1
13	ARROW STICKER	ARROW STICKER	PVC	1
14	TERMINAL STICKER	TERMINAL STICKER	PVC	1
15	ERTHING STICKER	ERTHING LEVEL	PVC	1
16	CHEESED SCREW	CHEESED SCREW M6X10	M.S.	5
17	SCREW	6X20	M.S.	6
18	SCREW CSK	END BUSH 5X10 (CSK)	M.S.	4
19	PLAIN WASHER	25X13.5X1.5	M.S.	1
20	TUBLER PIN	4X20 SHAFT FIXING TUBLER PIN	SPRING STEEL	2
21	TUBLER PIN	6X30 HANDLE FIXING TUBLER PIN	SPRING STEEL	1
22	SPRING WASHER	M8	SPRING STEEL	1
23	SPRING WASHER	M6	SPRING STEEL	13
24	PLAIN WASHER	13X6.5X1.5	M.S.	3
25	RIVET AB4	NAME PLATE FIXING	ALUMINIUM	4
26	HANDLE	266x54x25	M.S.	1
27	HEX BOLT	6X15, WAIGHT FIXING	M.S.	2
28	WEIGHT	SQ40X40X 72	M.S.	1

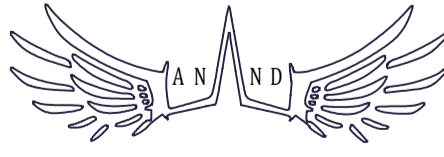
COMPANY NAME:  <b>ANAND SYSTEM ENGINEERING PVT LTD</b>		DO NOT SCALE DRAWING REVISION:
Email id: info@anandcontrol.in CONTACT NO: 9137620579		TITLE: <b>GRAVITY LIMIT SWITCH 1W 4C IP55 ASSEMBLY 2D</b>
DRAWN: SAURABH CHECKED: APPROVED: DATE: 18-12-2024	FINISH: SCALE:	SIGNATURE: SHEET: 1 OF 1