

# EXPLODED VIEW

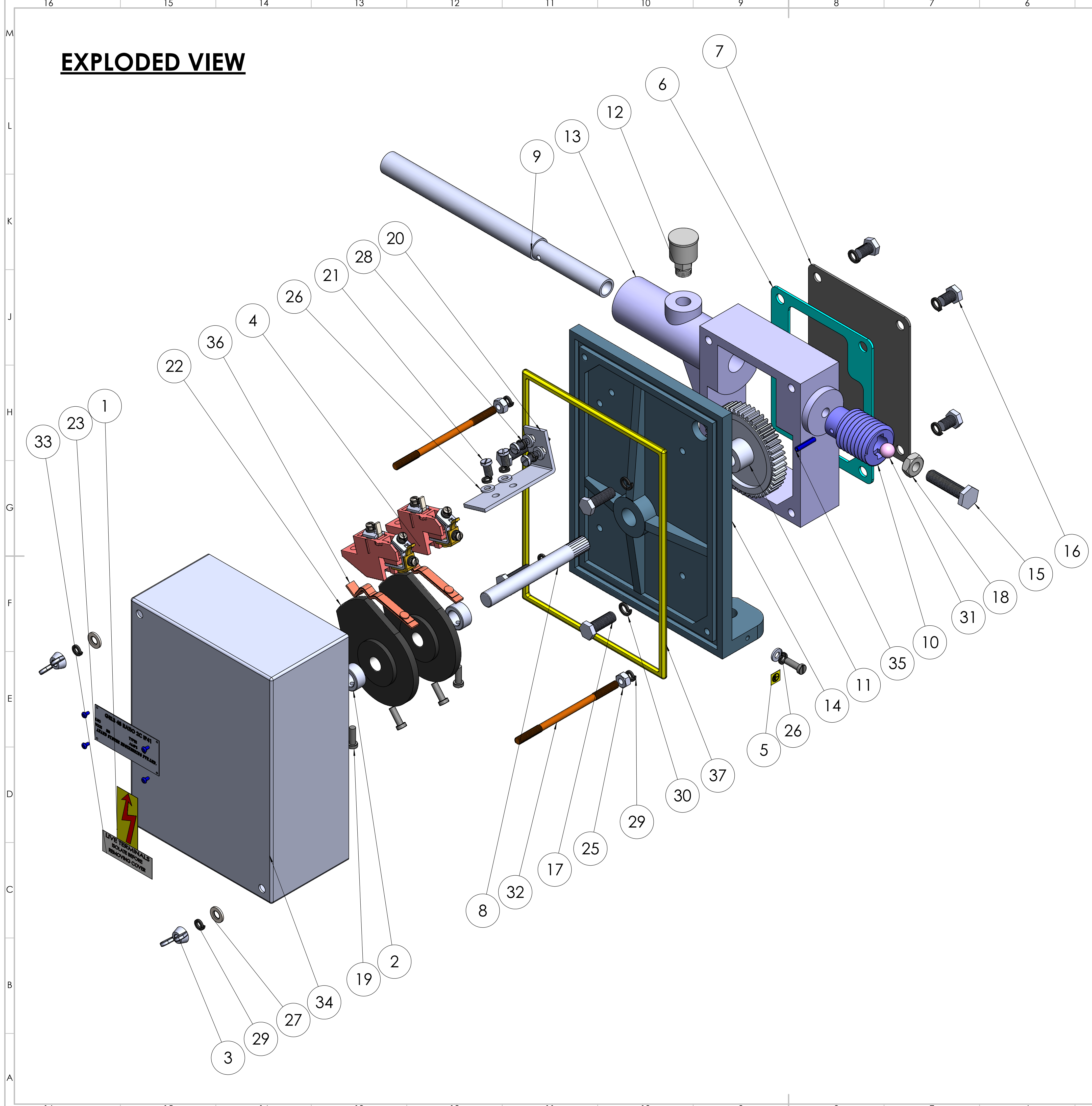

ITEM NO.	PART NUMBER	DESCRIPTION	MATERIAL	QTY.
1	ARROW STICKER	ARROW STICKER	-	1
2	BUSH	19X10X1/2" CAM FIXING	M.S.	2
3	BUTTERFLY NUT	1/4 MM COVER FIXING	M.S.	2
4	CONTACT BLOCK	CONTACT BLOCK ASSEMBLY IP-41 40AMP	-	2
5	ERTHING STICKER	ERTHING LEVEL	-	1
6	GASKET	MAIN BODY, 140X110X2	RUBBER	1
7	GEAR BOX COVER	140X110	M.S.	1
8	GEAR SHAFT	110X12.7	M.S.	1
9	GEAR WARM SHAFT	Ø 19X 245	M.S.	1
10	GEAR WARM SHAFT CAP	Ø 35 THREADING L- 49	PLASTIC	1
11	GEAR WORM WHEEL	RATIO 48:1, Ø 87	N6	1
12	GREASE CAP	Ø 22X18	PLASTIC	1
13	RLS BOTTOM GEAR BOX		CAST IRON	1
14	RLS BOTTOM MAIN BODY	223X170X70	CAST IRON	1
15	BOLT	10X40	M.S.	1
16	BOLT	8X12	M.S.	4
17	BOLT	8X25	M.S.	4
18	HEX NUT-M10	M 10 G.I.	M.S.	1
19	IMPELLER COVER AND TERMINAL SCREW	CHHS 5X15	M.S.	5
20	L- BRACKET	70X18.5X4 CONTACT ASSM FIXING	ALUMINIUM	1
21	SCREW	CHEESED M6X15	M.S.	4
22	MOLDED CAM (GRLS 2C IP41)	Ø 77	N6	2
23	NAME PLATE	72X34 (4 HOLES 2MM)	ALUMINIUM	1
24	NAME PLATE RIVET	AB4	ALUMINIUM	4
25	NUT 1-4	RB-1/4 NUT	M.S.	2
26	PLAIN WASHER	11X5.5X1.5	M.S.	5
27	PLAIN WASHER	13.5X6X1.5	M.S.	2
28	SPRING WASHER M5	M5X8.7X1.7	SPRING STEEL	4
29	SPRING WASHER M6	M6	SPRING STEEL	5
30	SPRING WASHER M8	M8	SPRING STEEL	8
31	STEEL BALL	Ø 12	STEEL	1
32	STUD	1/4"X110 MM	M.S.	2
33	TERMINAL STICKER(GRLS 2C IP41)	TERMINAL STICKER	-	1
34	TOP COVER	217X157X86	M.S.	1
35	TUBLER PIN	4X20 SHAFT FIXING TUBLER PIN	SPRING STEEL	1
36	CONTACT STRIP	CONTACT FIXING STRIPS	M.S.	2
37	ROUND GASKET GEAR BOX (2C IP41)	5MM	RUBBER	1

COMPANY NAME: **ANAND SYSTEM ENGINEERING PVT LTD**

DO NOT SCALE DRAWING

TITLE: **GRLS 48 RATIO 2C IP-41 ASSEMBLY 2D**

REVISION

EMAIL ID: [info@anandcontrol.in](mailto:info@anandcontrol.in)

CONTACT NO: [9137620579](tel:9137620579)

DWG-NO.

DATE

SIGNATURE

SCALE: 1:2

SHEET 1 OF 2

DATE: \_\_\_\_\_

SIGNATURE: \_\_\_\_\_

SCALE: 1:2

SHEET 1 OF 2



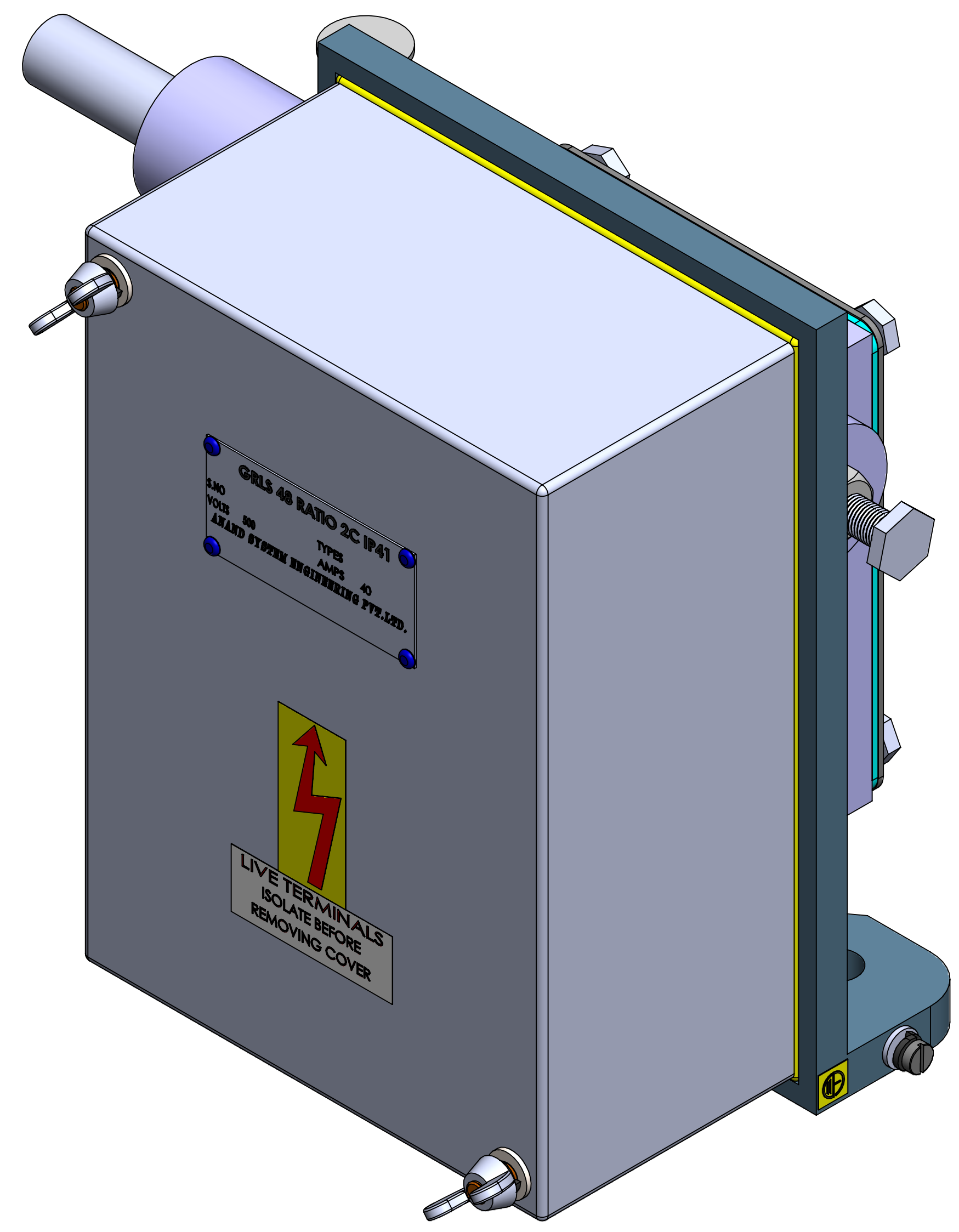
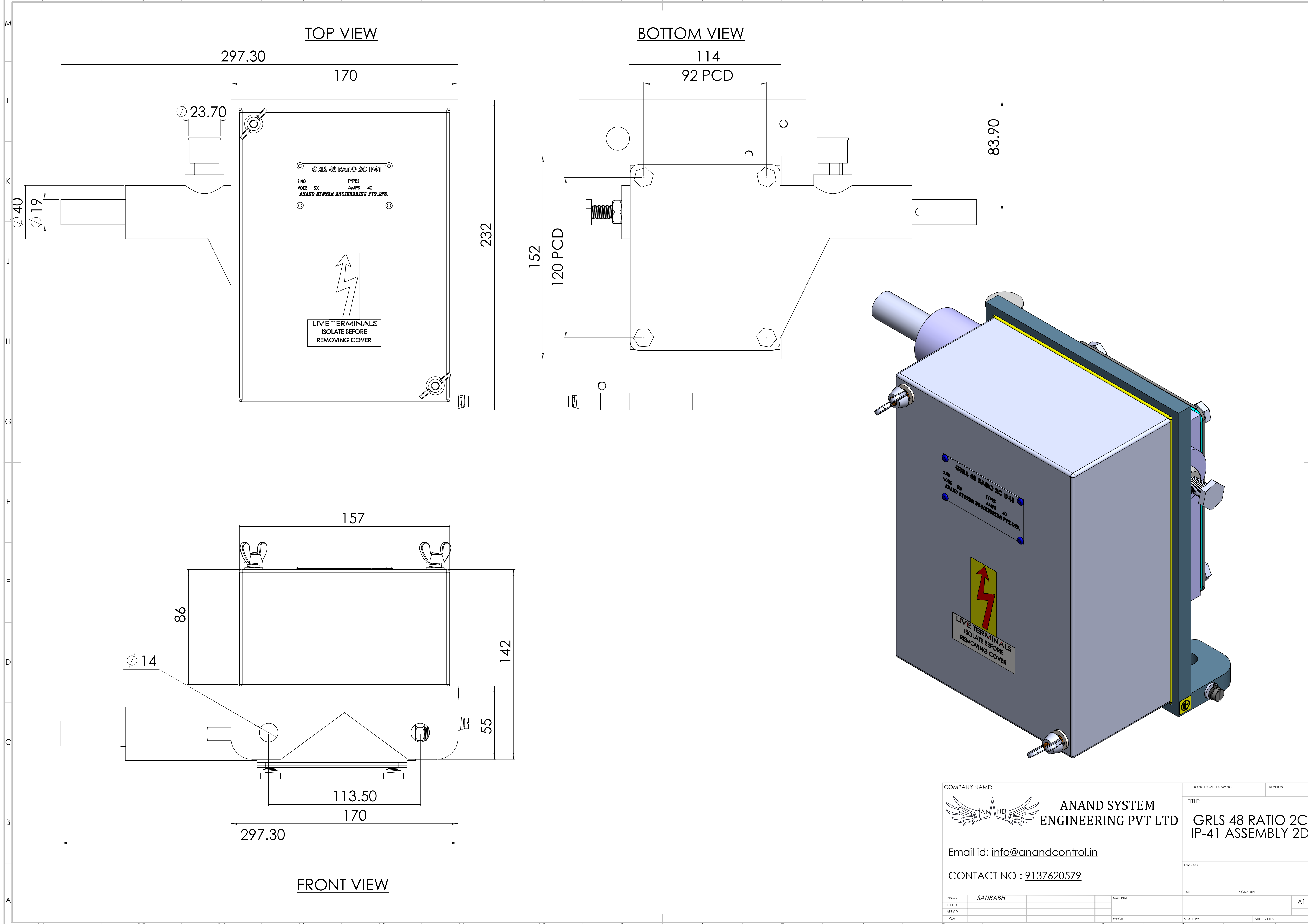

COMPANY NAME:		ANAND SYSTEM ENGINEERING PVT LTD		DO NOT SCALE DRAWING	REVISION
		<b>ANAND SYSTEM ENGINEERING PVT LTD</b>		TITLE:	
Email id: <a href="mailto:info@anandcontrol.in">info@anandcontrol.in</a>		CONTACT NO : <a href="tel:9137620579">9137620579</a>		GRLS 48 RATIO 2C IP-41 ASSEMBLY 2D	
DRAWN:	SAURABH	MATERIAL:		DATE:	SIGNATURE
CHK'D:					
APP'VD:					
Q.A.		WEIGHT:		SCALE:1:2	SHEET 2 OF 2